



**JLG® ULTRA SERIES BOOM LIFTS**

**JLG**  
reaching out.™

# JLG® ULTRA BOOMS REACHING OUT

Steel mills and chemical plants, airports, convention centers, shipyards and heavy construction. The JLG® Ultra Series boom lifts are designed for rugged job sites that demand you work higher and reach farther. With four decades of experience, JLG knows the territory. You need the power, reliability and versatility to do the impossible every day. And come back and do it again tomorrow.

JLG Ultra Series boom lifts get you there. They're built from 100,000 psi steel—40% stronger than the competition, and they'll lift 1,000 pounds, making them the most powerful booms in the industry.

When you're working ten stories high, you want a machine that gives you confidence to do your best work; that's built to perform and that's designed to meet any challenge—that's the JLG Ultra Series.

## REACHING OUT FOR ULTIMATE PRODUCTIVITY

*"No other machine allows us to reach  
as high or as far."*





**GO EVERYWHERE  
YOU NEED TO GO**



## MAXIMUM HEIGHT, REACH AND POWER

When your job demands both height and reach, enlist the JLG® Model 1250AJP. With over 60 ft of up and over height and 63 ft of outreach, the 1250AJP is ideal for applications that require high-reach versatility. Automatic platform leveling provides operator comfort at 125 ft. While the exclusive QuikStik® boom design delivers faster cycle speeds—115 seconds from ground to elevation—so you can get work done quickly and efficiently. JLG Ultra Series boom lifts come with the only oscillating axle in their boom class, giving you surprising mobility in an ultra-sized package.

*“The larger platform gives us more room for tools and extra workers.”*

## FEATURES



### Unmatched Range of Motion

With up and over height of 60 ft 6 in. (18.44 m) and 63 ft 2 in. (19.25 m) of horizontal outreach, the 1250AJP gets you where you need to work.



### Extendable Axles

Cylinder-deployed axles allow these boom lifts to grow from their transport width of 8' 2" to as wide as 16' 6" for unmatched rigidity and stability.



### JibPLUS®

JibPLUS provides select Ultra Series models with up to 180 degrees of horizontal maneuverability for added versatility and improved productivity.



### Four-Wheel Steering

All of our Ultra Series boom lifts offer 3 steering modes to meet the needs of diverse and ever-changing job sites.

Ultra Series  
TELESCOPIC BOOM LIFTS



**Strong 100,000 PSI Steel**

The high-quality steel of the boom ensures greater durability and stability.



**Larger Work Envelope**

With more outreach above 50 ft, you have added access and flexibility.

## TAKING PRODUCTIVITY TO GREATER HEIGHTS

Dominate the job site with the JLG® Ultra Series. When you're facing tall challenges, you want a solid machine that goes above and beyond the day's demands. The rugged boom gives you the confidence and support you need to handle 1,000 lb capacity. The exclusive controlled arc regulates speeds at the edges of the work envelope so that you feel the same velocity in all positions for enhanced comfort.

*"The high capacity platforms raise our productivity, and level of work."*



### Oscillating Axle

Standard on all Ultra Booms, oscillating axle and full-time four-wheel drive provide superior traction.



### SkyPower®

A 7,500-watt on-board generator gives you the extra boost you need.

## EXTEND YOUR REACH WITH THE 1500SJ

The Model 1500SJ is the largest self-propelled telescopic boom available from JLG—the first straight boom lift that takes you to 150 ft without an oversized load permit (over weight permit is required for highway transportation). The 1500SJ features a telescoping jib for greater work envelope flexibility and additional outreach at elevation.

*“At 150 ft, I want to focus on my work with confidence. The Ultra Series lets me do just that.”*



### More Capacity

With a dual 1,000/500 lb capacity, the platform can handle more workers, tools or materials.



### Greater Reach

The JibPLUS® boom adds an extra 30 ft of outreach.\*

\*Capacity restricted to 500 lb (227 kg) when the jib is in side-swing mode. JibPLUS for transport only for 1500SJ.





**More Maneuverability**

Full-time four-wheel drive gets you over rough terrain.



**Ease of Transport**

No oversized load permit needed.

## GO WHERE NO BOOM HAS GONE BEFORE WITH CONFIDENCE AT 185 FT

Introducing the highest reaching telescopic, self-propelled boom lift to ever hit the market. The 1850SJ features 19 stories of working height and a brand new chassis. The 1850SJ is much faster to full height, so operators can spend more time working and less time positioning the boom. The axles take approximately one minute to extend or retract. They're able to pivot in and out and do not telescope like extendable axles on other Ultra Series boom lifts.

### Greater Work Envelope

Telescoping jib and five section boom provides 2.9 million cubic feet of work area and greater ability to reach up and over. Plus, the operator can move just the jib, rather than the whole machine, for greater maneuverability and more precise positioning.

*"I've never felt more confident  
working from a machine of this caliber."*



### New Chassis

Each axle is equipped with a linear sensor that works with the rotary sensor to keep steer wheels in the proper position.



### No Permits Needed

Easy to transport because no oversized load permit is needed (over weight permit is required for highway transportation).



### LCD Screen

An LCD screen shows operators where they are in the work envelope along with other useful information.



### Travel and Gradeability

Travel is permitted with platform at full elevation and features 40% gradeability.

## WORKSTATION IN THE SKY® ACCESSORIES

Turn your engine powered aerial work platform into an integrated work tool with Workstation in the Sky® accessories. These packages are designed to increase your productivity, conserve platform space and improve working conditions.

### SKYPOWER® PACKAGE

Machines with the SkyPower® system are equipped with a self-contained 7500W continuous output generator with a power cable, and an air/water line installed in the power track. In addition, it provides self-contained 110V-AC, 220V-AC and 3-phase power to run other accessories and hand tools.



### NITE BRIGHT® PACKAGE

This package consists of 40-watt lights to illuminate your work site and the area around the chassis for increased visibility. It is perfect for tunnel or mine applications, nighttime work or any job with low lighting levels.



### SKYCUTTER® PACKAGE

Eliminating the danger of tanks and draping hoses, SkyCutter® cuts faster and cleaner with an on-board Miller® Spectrum 375 Cutmate plasma cutter.



### SKYWELDER® PACKAGE

With a 280 amp Miller® CST 280 welder tucked into the SkyPower platform, space is conserved while providing stick and TIG capability. The SkyWelder® package eliminates potentially dangerous leads hanging over the rails and the unnecessary cost of a stand-alone welder and power supply.



### SKYGLAZIER® PACKAGE

The first and only factory-approved glass and panel tray. Panels are protected from damage and productivity is improved while operator fatigue is reduced. And with JLG® 1,000 lb capacity, the basket can hold multiple workers and larger glass panels.



### SKYAIR® PACKAGE

With an integrated on-board air compressor, the SkyAir® package delivers 9.3 CFM at pressures up to 125 psi. It increases productivity by eliminating the need for a ground-based compressor.



### PIPE RACK ACCESSORY

Manufacturer-approved pipe racks provide positive retention of materials while storage outside the platform helps prevent rail damage and optimizes space.





## PUTTING YOUR WORK ABOVE EVERYTHING

When it comes to JLG® Ground Support, it's all about you. Your productivity. Your profitability. Your uptime. From the purchase of your first piece of equipment straight through to the training, parts and maintenance that follows.



### ■ Customer Service Call Center

You can be assured we'll be giving an all-out effort to support you. Just think of us as your personal on-call, full-service support team. We make it happen. Period.

### ■ Financial Solutions

Maximizing your profits. Preserving your cash flow. Let our financing specialists help choose the program designed specifically for your needs.

### ■ Aftermarket Parts

Keep your equipment running at peak performance with genuine replacement parts, accessories, attachments, rebuilt and competitive parts all from one source — JLG.

### ■ Training

Knowing your equipment inside and out results in higher productivity on the job. Our instructor-led courses give you the hands-on time you need for success.

### ■ Service Centers

Your needs. Your uptime. JLG is on the job to fulfill your every need, from repair, reconditioning, same-day parts and much more. We're here to support you.

1250AJP

Ultra Series Articulating Boom Lifts

Reach Specifications

Platform Height	125 ft (38.1 m)
Horizontal Reach	63 ft 2 in. (19.25 m)
Up and Over Height	60 ft 6 in. (18.44 m)
Swing	360° Continuous
Platform Capacity — Restricted	1,000 lb (454 kg)
Platform Capacity — Unrestricted	500 lb (227 kg)
Platform Rotator	180°
JibPLUS <sup>1</sup>	Length 8 ft (2.44 m)
	Horizontal Motion <sup>1</sup> 125°
	Vertical Motion 130° (+75/-55)

Dimensional Data

A. Platform Size	36 x 96 in. (0.91 x 2.44 m)
B. Overall Width	Axles Retracted 8 ft 2 in. (2.49 m)
	Overall Width Axles Extended 12 ft 6 in. (3.81 m)
C. Tailswing	3 ft (91 cm)
D. Stowed Height	10 ft (3.05 m)
E. Overall Length	Jib Stowed 37 ft 7 in. (11.45 m)
	Overall Length Jib Deployed 47 ft 6 in. (14.48 m)
F. Wheel Base	12 ft 6 in. (3.81 m)
G. Ground Clearance	Axle 12 in. (30 cm)
	Chassis 25.5 in. (65 cm)
Weight <sup>2</sup>	44,000 lb (19,958 kg)

Chassis

Max Ground Bearing Pressure*	100 psi (7.03 kg/cm <sup>2</sup> )
Drive Speed	3.25 mph (5.2 km/h)
Gradeability	45%
Turning Radius (Inside)	Axles Retracted 14 ft 5 in. (4.39 m)
	Axles Extended 8 ft (2.44 m)
Turning Radius (Outside)	Axles Retracted 22 ft 6 in. (6.86 m)
	Axles Extended 19 ft 4 in. (5.89 m)
Crab Steer Ratio <sup>3</sup>	1:1
Axle Oscillation	8 in. (20 cm)
Tires/Type	445/50D710 Foam Filled

Power Source

Diesel Engine	Deutz TCD2.9L4 Tier 4 Final	74.2 hp (55.4 kW)
Fuel Tank Capacity	31 gal (117 L)	
Hydraulic Reservoir	53 gal (200 L)	
Auxiliary Power	12V DC	
Generator Nominal/Continuous	7,500 Watt	

\*Ground bearing pressure applies to standard tires.

- Capacity is limited to 500 lb (227 kg) when JibPLUS is extended horizontally.
- Certain options or country standards increase weight.
- Ratio of forward travel to lateral travel.

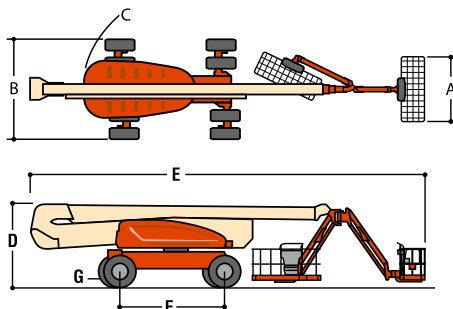

Standard Features

- Platform: 36 x 96 in. (0.91 x 2.44 m) Side Entry
- 8 ft (2.44 m) JibPLUS<sup>1</sup> Boom
- Selectable Capacity Envelope
- 180° Hydraulic Platform Rotator
- AC Receptacle in the Platform
- SkyPower<sup>®</sup> Package
  - 7500 Watt Generator
  - 240/120V Single Phase
  - 240V 3 Phase
- 1/2 in. Air Line to Platform
- 5 Degree Tilt Alarm/Indicator Light
- All Motion Alarm
- Swing-Out Engine Tray
- 12V DC Auxiliary Power
- Hourmeter
- Control ADE<sup>®</sup> System
- Full-time 4WD
- 3 Selectable Steering Modes
- Drive-out Extendible Axles
- Oscillating Axle
- Proportional Controls
- Gull-Wing Hoods
- 445/50D710 Foam Filled Rim Protector Lug Tread Tires
- Platform Console Machine Status Light Panel\*
- Lifting/Tie Down Lugs
- Engine Distress Warning/Shutdown — Selectable via JLG Analyzer

Available Options

- Platform: 36 x 72 in. (0.91 x 1.83 m) Side Entry
- Fall-Arrest Platform: 36 x 96 in. (0.91 x 2.44 m) Side Entry
- Self-Closing Gate
- Light Package<sup>1</sup>
- Flashing Beacon
- Soft-Touch System Platform 6 ft/8 ft (1.83 m/2.44 m)
- Clearsky (US and Canada only)
- Cold Weather Start<sup>2</sup>
- Hostile Environment Kit<sup>3</sup>
- Mesh to Top Rail
- Operator Tool Tray

  - Includes platform mounted work lights and drive/backup lights.
  - Includes glow plugs, battery heater and oil tank heater.
  - Includes console cover, boom wipers and cylinder bellows.

Accessory Packages

- SkyWelder<sup>®</sup>
- SkyCutter<sup>®</sup>
- SkyGlazier<sup>®</sup>
- Nite Bright<sup>®</sup>
- Pipe Racks

\* Provides indicator lights at platform control console for system distress, fuel level, low fuel, 5 degree tilt light and foot switch status.

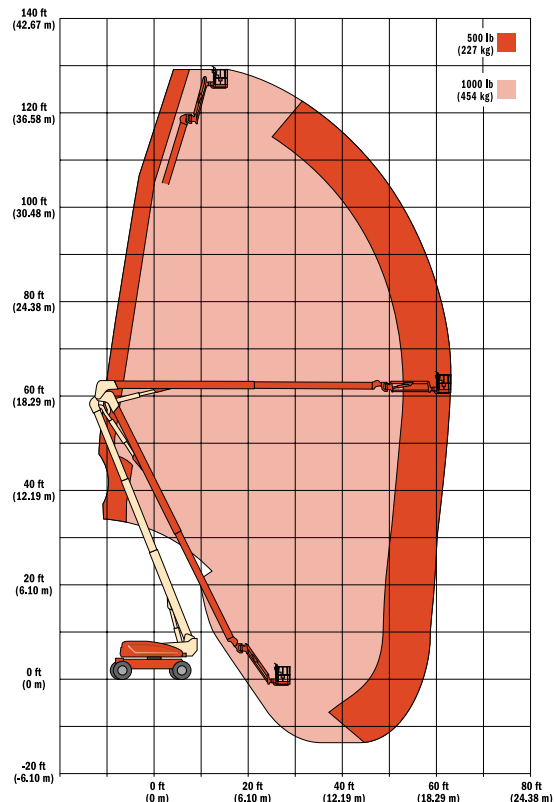

# Ultra Series SPECIFICATIONS

## 1200SJP

### Ultra Series Telescopic Boom Lifts

#### Reach Specifications

Platform Height	120 ft (36.58 m)
Horizontal Reach	75 ft (22.86 m)
Up and Over Height	—
Swing	360° Continuous
Platform Capacity — Restricted	1,000 lb (454 kg)
Platform Capacity — Unrestricted	500 lb (227 kg)
Platform Rotator	180°
JibPLUS <sup>®</sup>	
Length	8 ft (2.44 m)
Horizontal Motion <sup>1</sup>	180°
Vertical Motion	130° (+75/-55)

#### Dimensional Data

A. Platform Size	36 x 96 in. (0.91 x 2.44 m)
B. Overall Width	Axles Retracted 8 ft 2 in. (2.49 m)
Overall Width	Axles Extended 12 ft 6 in. (3.81 m)
C. Tailswing	5 ft 6 in. (1.67 m)
D. Stowed Height	10 ft (3.05 m)
E. Overall Length	Jib Stowed 34 ft 11 in. (10.64 m)
Overall Length	Jib Deployed 44 ft 10.25 in. (13.67 m)
F. Wheel Base	12 ft 6 in. (3.81 m)
G. Ground Clearance	Axle 12 in. (30 cm)
Chassis	25.5 in. (65 cm)
Weight <sup>2</sup>	40,900 lb (18,552 kg)

#### Chassis

Max Ground Bearing Pressure*	99 psi (7.0 kg/cm <sup>2</sup> )
Drive Speed	3.25 mph (5.2 km/h)
Gradeability	45%
Turning Radius (Inside)	Axles Retracted 14 ft 5 in. (4.39 m)
	Axles Extended 8 ft (2.44 m)
Turning Radius (Outside)	Axles Retracted 22 ft 6 in. (6.86 m)
	Axles Extended 19 ft 4 in. (5.89 m)
Crab Steer Ratio <sup>3</sup>	1:1
Axle Oscillation	12 in. (30 cm)
Tires/Type	445/50D710 Foam Filled

#### Power Source

Diesel Engine	Deutz TCD2.9L4 Tier 4 Final	74.2 hp (55.4 kW)
Fuel Tank Capacity		31 gal (117 L)
Hydraulic Reservoir		55 gal (208 L)
Auxiliary Power		12V DC
Generator		7500 Watt

\*Ground bearing pressure applies to standard tires.

- Capacity is limited to 500 lb (227 kg) when JibPLUS is extended horizontally.
- Certain options or country standards increase weight.
- Ratio of forward travel to lateral travel.

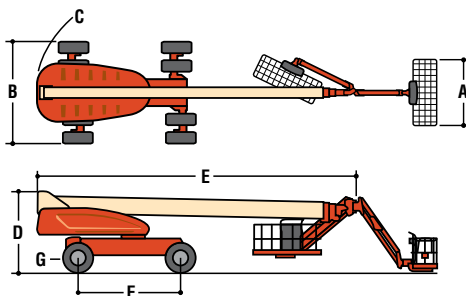

#### Standard Features

Platform: 36 x 96 in. (0.91 x 2.44 m) Side Entry  
 8 ft (2.44 m) JibPLUS<sup>®</sup> Boom  
 Selectable Capacity Envelope  
 180° Hydraulic Platform Rotator  
 AC Receptacle in the Platform  
 SkyPower<sup>®</sup> Package  
 7500 Watt Generator  
 · 240/120V Single Phase  
 · 240V 3 Phase  
 1/2 in. Air Line to Platform  
 5 Degree Tilt Alarm/Indicator Light  
 All Motion Alarm  
 Swing-Out Engine Tray  
 12V DC Auxiliary Power  
 Hourmeter  
 Control ADE<sup>®</sup> System  
 Full-time 4WD  
 3 Selectable Steering Modes  
 Drive-out Extendible Axles  
 Oscillating Axle  
 Proportional Controls  
 Gull-Wing Hoods  
 445/50D710 Foam Filled Rim Protector Lug Tread Tires  
 Platform Console Machine Status Light Panel\*  
 Lifting/Tie Down Lugs  
 Engine Distress Warning/Shutdown—Selectable via JLG Analyzer

#### Available Options

Platform: 36 x 72 in. (0.91 x 1.83 m) Side Entry  
 Fall-Arrest Platform: 36 x 96 in. (0.91 x 2.44 m) Side Entry  
 Self-Closing Gate  
 Light Package<sup>1</sup>  
 Flashing Beacon  
 Soft-Touch System Platform 6 ft/8 ft (1.83 m/2.44 m)  
 Clearsky (US and Canada only)  
 Cold Weather Start<sup>2</sup>  
 Hostile Environment Kit<sup>3</sup>  
 Mesh to Top Rail  
 Operator Tool Tray  
 1. Includes platform mounted work lights and drive/backup lights.  
 2. Includes glow plugs, battery heater and oil tank heater.  
 3. Includes console cover, boom wipers and cylinder bellows.

#### Accessory Packages

SkyWelder<sup>®</sup>  
 SkyCutter<sup>®</sup>  
 SkyAir<sup>®</sup> (1200/1350SJP only)  
 SkyGlazier<sup>®</sup>  
 Nite Bright<sup>®</sup>  
 Pipe Racks

\* Provides indicator lights at platform control console for system distress, fuel level, low fuel, 5 degree tilt light and foot switch status.

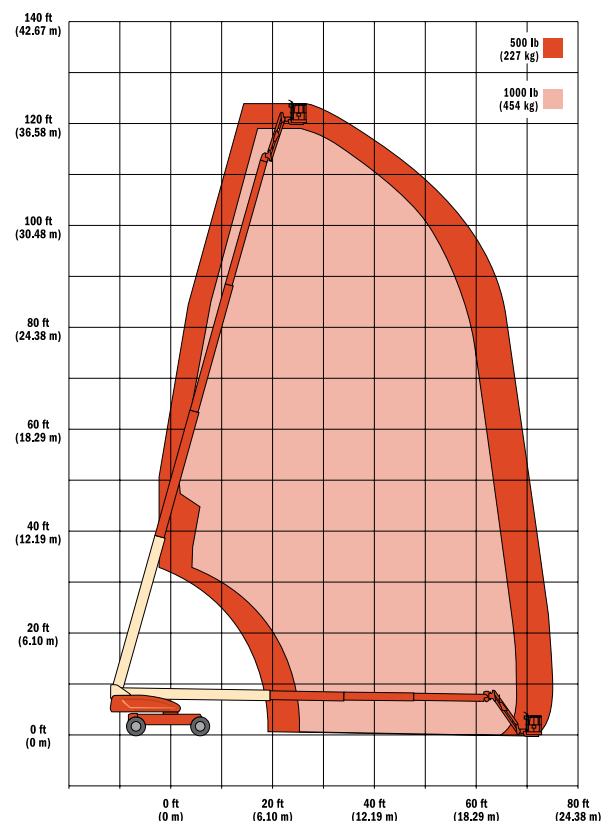



1350SJP

Ultra Series Telescopic Boom Lifts

Reach Specifications

Platform Height	135 ft (41.15 m)
Horizontal Reach	80 ft (24.38 m)
Up and Over Height	—
Swing	360° Continuous
Platform Capacity — Restricted	1,000 lb (454 kg)
Platform Capacity — Unrestricted	500 lb (227 kg)
Platform Rotator	180°
JibPLUS <sup>®</sup>	
Length	8 ft (2.44 m)
Horizontal Motion <sup>1</sup>	180°
Vertical Motion	130° (+75/-55)

Dimensional Data

A. Platform Size	36 x 96 in. (0.91 x 2.44 m)
B. Overall Width	Axles Retracted 8 ft 2 in. (2.49 m)
Overall Width	Axles Extended 12 ft 6 in. (3.81 m)
C. Tailswing	5 ft 6 in. (1.67 m)
D. Stowed Height	10 ft (3.05 m)
E. Overall Length	Jib Stowed 38 ft 11 in. (11.86 m)
Overall Length	Jib Deployed 48 ft 10.25 in. (14.89 m)
F. Wheel Base	12 ft 6 in. (3.81 m)
G. Ground Clearance	Axle 12 in. (30 cm)
Chassis 25.5 in. (65 cm)	
Weight <sup>2</sup>	45,000 lb (20,411 kg)

Chassis

Max Ground Bearing Pressure*	107 psi (7.52 kg/cm <sup>2</sup> )
Drive Speed	3.25 mph (5.2 km/h)
Gradeability	45%
Turning Radius (Inside)	Axles Retracted 14 ft 5 in. (4.39 m)
Axles Extended 8 ft (2.44 m)	
Turning Radius (Outside)	Axles Retracted 22 ft 6 in. (6.86 m)
Axles Extended 19 ft 4 in. (5.89 m)	
Crab Steer Ratio <sup>3</sup>	1:1
Axle Oscillation	12 in. (30 cm)
Tires/Type	445/50D710 Foam Filled

Power Source

Diesel Engine	Deutz TCD2.9L4 Tier 4 Final	74.2 hp (55.4 kW)
Fuel Tank Capacity		31 gal (117 L)
Hydraulic Reservoir		55 gal (208 L)
Auxiliary Power		12V DC
Generator Nominal/Continuous		7,500 Watt

\*Ground bearing pressure applies to standard tires.

- Capacity is limited to 500 lb (227 kg) when JibPLUS is extended horizontally.
- Certain options or country standards increase weight.
- Ratio of forward travel to lateral travel.

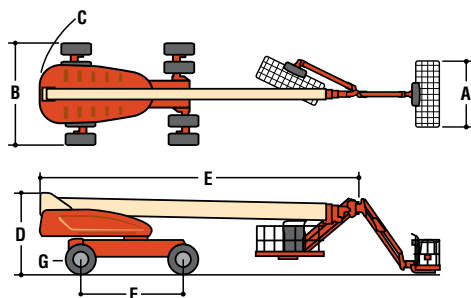

Standard Features

- Platform: 36 x 96 in. (0.91 x 2.44 m) Side Entry
- 8 ft (2.44 m) JibPLUS<sup>®</sup> Boom
- Selectable Capacity Envelope
- Inward Swinging Gate
- 180° Hydraulic Platform Rotator
- AC Receptacle in the Platform
- SkyPower<sup>®</sup> Package
  - 7500 Watt Generator
  - 240/120V Single Phase
  - 240V 3 Phase
  - 1/2 in. Air Line to Platform
- 5 Degree Tilt Alarm/Indicator Light
- All Motion Alarm
- Swing-Out Engine Tray
- 12V DC Auxiliary Power
- Hourmeter
- Control ADE<sup>®</sup> System
- Full-time 4WD
- 3 Selectable Steering Modes
- Drive-out Extendible Axles
- Oscillating Axle
- Proportional Controls
- Gull-Wing Hoods
- 445/50D710 Foam Filled Rim Protector Lug Tread Tires
- Platform Console Machine Status Light Panel\*
- Lifting/Tie Down Lugs
- Engine Distress Warning/Shutdown—Selectable via JLG Analyzer

Available Options

- Platform: 36 x 72 in. (0.91 x 1.83 m) Side Entry
- Fall-Arrest Platform: 36 x 96 in. (0.91 x 2.44 m) Side Entry
- Self-Closing Gate
- Light Package<sup>1</sup>
- Flashing Beacon
- Soft-Touch System Platform 6 ft/8 ft (1.83 m/2.44 m)
- Clearsky (US and Canada only)
- Cold Weather Start<sup>2</sup>
- Hostile Environment Kit<sup>3</sup>
- Mesh to Top Rail
- Operator Tool Tray
- 1. Includes platform mounted work lights and drive/backup lights.
- 2. Includes glow plugs, battery heater and oil tank heater.
- 3. Includes console cover, boom wipers and cylinder bellows.

Accessory Packages

- SkyWelder<sup>®</sup>
- SkyCutter<sup>®</sup>
- SkyAir<sup>®</sup> (1200/1350SJP only)
- SkyGlazier<sup>®</sup>
- Nite Bright<sup>®</sup>
- Pipe Racks

\* Provides indicator lights at platform control console for system distress, fuel level, low fuel, 5 degree tilt light and foot switch status.

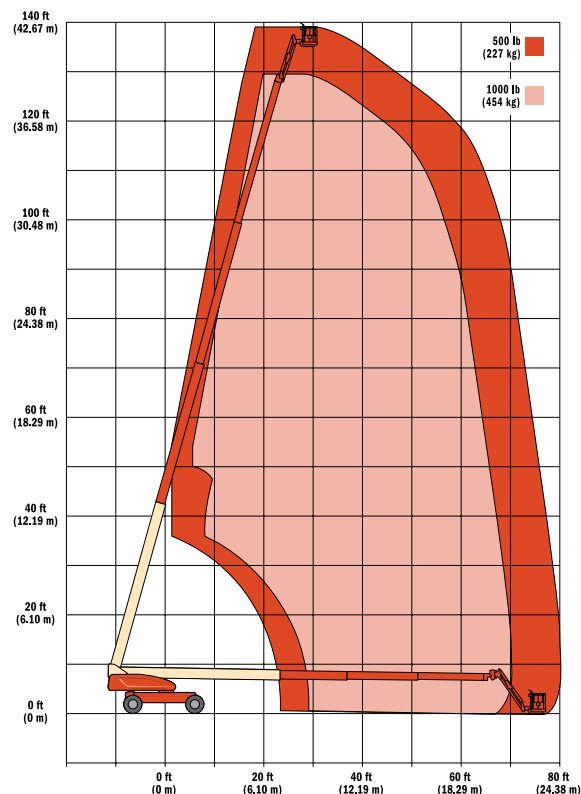

# Ultra Series SPECIFICATIONS

## 1500SJ

### Ultra Series Telescopic Boom Lifts

#### Reach Specifications

Platform Height	150 ft (45.7 m)	
Horizontal Reach	80 ft (24.38 m)	
Up and Over Height	—	
Swing	360° Continuous	
Platform Capacity — Restricted	1,000 lb (454 kg)	
Platform Capacity — Unrestricted	500 lb (227 kg)	
Platform Rotator	180°	
Jib	Length	15 ft 2 in. - 25 ft (4.62 m - 7.62 m)
	Horizontal Motion <sup>1</sup>	For Transport Only
	Vertical Motion	120° (+75/-45)

#### Dimensional Data

A. Platform Size	36 x 96 in. (0.91 x 2.44 m)	
B. Overall Width	Axles Retracted	8 ft 2 in. (2.49 m)
	Axles Extended	12 ft 6 in. (3.81 m)
C. Tailswing	5 ft 6 in. (1.67 m)	
D. Stowed Height	10 ft (3.05 m)	
E. Overall Length	Jib Stowed	43 ft (11.45 m)
	Jib Deployed	61 ft 9 in. (18.82 m)
F. Wheel Base	12 ft 6 in. (3.81 m)	
G. Ground Clearance	Axle	12 in. (30 cm)
	Chassis	25.5 in. (65 cm)
Weight <sup>2</sup>	48,000 lb (21,773 kg)	

#### Chassis

Max Ground Bearing Pressure*	113 psi (7.94 kg/cm <sup>2</sup> )	
Drive Speed	3.0 mph (4.8 km/h)	
Gradeability	40%	
Turning Radius (Inside)	Axles Retracted	14 ft 5 in. (4.39 m)
	Axles Extended	8 ft (2.44 m)
Turning Radius (Outside)	Axles Retracted	22 ft 6 in. (6.86 m)
	Axles Extended	19 ft 4 in. (5.89 m)
Crab Steer Ratio <sup>3</sup>	1:1	
Axle Oscillation	12 in. (30 cm)	
Tires/Type	445/50D710 Foam Filled	

#### Power Source

Diesel Engine	Deutz TCD2.9L4 Tier 4 Final	74.2 hp (55.4 kW)
Fuel Tank Capacity	31 gal (117 L)	
Hydraulic Reservoir	55 gal (208 L)	
Auxiliary Power	12V DC	
Generator	7,500 Watt	

\*Ground bearing pressure applies to standard tires.

- Capacity is limited to 500 lb (227 kg) when Jib is extended.
- Certain options or country standards increase weight.
- Ratio of forward travel to lateral travel.

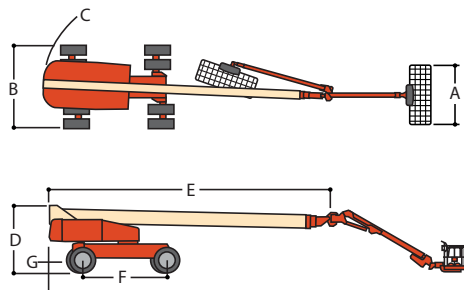

#### Standard Features

Platform: 36 x 96 in. (0.91 x 2.44 m) Side Entry  
 8 ft (2.44 m) JibPLUS<sup>®</sup> Boom  
 Selectable Capacity Envelope  
 180° Hydraulic Platform Rotator  
 AC Receptacle in the Platform  
 SkyPower<sup>®</sup> Package  
 7500 Watt Generator  
 - 240/120V Single Phase  
 - 240V 3 Phase  
 1/2 in. Air Line to Platform  
 5 Degree Tilt Alarm/Indicator Light  
 All Motion Alarm  
 Swing-Out Engine Tray  
 12V DC Auxiliary Power  
 Hourmeter  
 Control ADE<sup>®</sup> System  
 Full-time 4WD  
 3 Selectable Steering Modes  
 Drive-out Extendible Axles  
 Oscillating Axle  
 Proportional Controls  
 Gull-Wing Hoods  
 445/50D710 Foam Filled Rim  
 Protector Lug Tread Tires  
 Platform Console Machine Status  
 Light Panel\*  
 Lifting/Tie Down Lugs  
 Engine Distress Warning/Shutdown—  
 Selectable via JLG Analyzer

\* Provides indicator lights at platform control console for system distress, fuel level, low fuel, 5 degree tilt light and foot switch status.

#### Available Options

Platform: 36 x 72 in. (0.91 x 1.83 m) Side Entry  
 Fall-Arrest Platform: 36 x 96 in. (0.91 x 2.44 m) Side Entry  
 Self-Closing Gate  
 Light Package<sup>1</sup>  
 Flashing Beacon  
 Soft-Touch System Platform  
 6 ft/8 ft (1.83 m/2.44 m)  
 Clearsky (US and Canada only)  
 Cold Weather Start<sup>2</sup>  
 Hostile Environment Kit<sup>3</sup>  
 Mesh to Top Rail  
 Operator Tool Tray  
 1. Includes platform mounted work lights and drive/backup lights.  
 2. Includes glow plugs, battery heater and oil tank heater.  
 3. Includes console cover, boom wipers and cylinder bellows.

#### Accessory Packages

SkyWelder<sup>®</sup>  
 SkyCutter<sup>®</sup>  
 SkyAir<sup>®</sup> (1200/1350SJ only)  
 SkyGlazier<sup>®</sup>  
 Nite Bright<sup>®</sup>  
 Pipe Racks

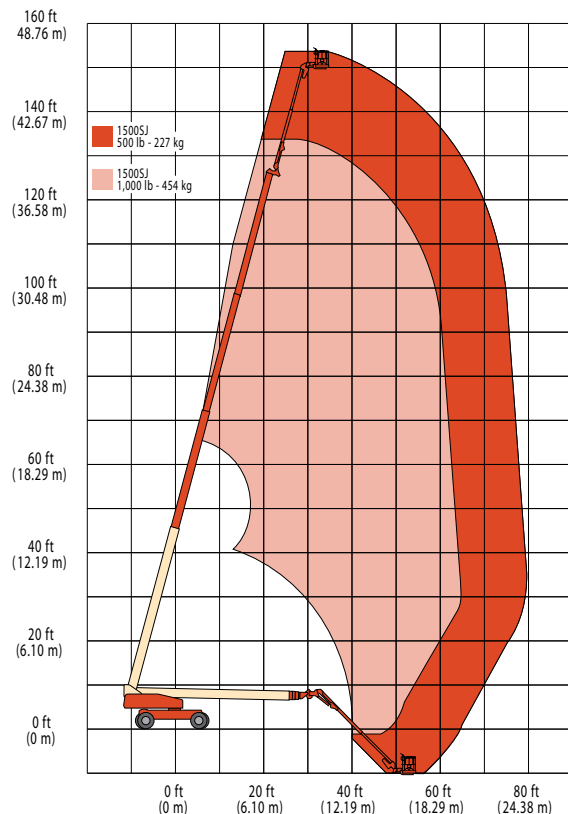

1850SJ

Ultra Series Telescopic Boom Lifts

Reach Specifications

Platform Height	185 ft 7 in. (56.56 m)	
Horizontal Reach	80 ft (24.38 m)	
Swing	360° Continuous	
Platform Capacity — Restricted	1,000 lb (454 kg)	
Platform Capacity — Unrestricted	500 lb (227 kg)	
Platform Rotator	173° Hydraulic	
Jib	Length	13 ft (3.96 m)
	Horizontal Motion <sup>1</sup>	For Transport Only
	Vertical Motion	120° (+75/-45)

Dimensional Data

A. Platform Size	36 x 96 in. (.91 x 2.44 m)		
B. Overall Width	Axles Retracted	8 ft 2 in. (2.49 m)	
	Overall Width	Axles Extended	16 ft 6 in. (5.03 m)
C. Tailswing	7 ft 7 in. (2.32 m)		
D. Stowed Height	10 ft (3.05 m)		
E. Overall Length	Jib Stowed	47 ft 9.5 in. (14.57 m)	
	Overall Length	Jib Deployed	63 ft 10 in. (19.45 m)
F. Wheel Base	17 ft 7 in. (5.36 m)		
G. Ground Clearance	Axle	13.5 in. (34 cm)	
	Chassis	16.25 in. (41 cm)	
Weight <sup>1</sup>	60,300 lb (27,352 kg)		

Chassis

Max Ground Bearing Pressure*	119.6 psi (8.41 kg/cm <sup>2</sup> )	
Drive Speed	2.8 mph (4.5 km/h)	
Gradeability	40%	
Turning Radius (Inside)	Axles Retracted	23 ft 4 in. (7.12 m)
	Axles Extended	7 ft 7 in. (2.3 m)
Turning Radius (Outside)	Axles Retracted	31 ft 3 in. (9.52 m)
	Axles Extended	21 ft 8 in. (6.6 m)
Crab Steer Ratio <sup>3</sup>	1:1	
Tires/Type	445/50D710 Foam Filled	

Power Source

Diesel Engine	Deutz TD3.6L	99.8 hp (74.4 kW)
Fuel Tank Capacity	52.8 gal (200 L)	
Hydraulic Reservoir	75.1 gal (284.2 L)	
Auxiliary Power	12V DC	
Generator	7,500 Watt	

\*Ground bearing pressure applies to standard tires.

- Capacity is limited to 500 lb (227 kg) when Jib is extended.
- Certain options or country standards increase weight.
- Ratio of forward travel to lateral travel.

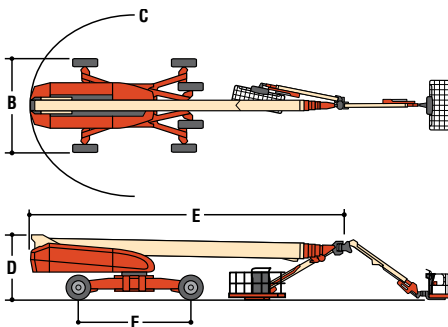

Standard Features

- Platform 36 x 96 in. (.91 x 2.44 m) Side Entry
- Selectable Capacity Envelope
- Drive-Out Extendable Axles
- 180° Hydraulic Platform Rotator
- AC Receptacle in Platform
- Tilt Light and Alarm
- Swing-Out Engine Tray
- 12V-DC Auxiliary Power
- Hourmeter
- Control ADE® System
- Full-Time 4WD
- 3 Selectable Steering Modes
- Proportional Controls
- Gull-Wing Steel Hoods
- 445/50D710 Foam-Filled Rim Protector Lug Tread Tires
- Platform Console Machine Status Light Panel\*
- Lifting/Tie Down Lugs
- Engine Distress Warning/Shutdown—Selectable via JLG Analyzer
- All Motion Alarm
- Glow Plugs
- LCD Panel at Operator's Platform Control Console

\* Provides indicator lights at platform control console for system distress, fuel level, low fuel, 5 degree tilt light and foot switch status.

Available Options

- 36 x 72 in. (.91 x 1.83 m) Platform
- Inward Self-Closing Swing Gate
- Fall Arrest Platform 36 x 96 in. (.91 x 2.44 m) Rear Entry
- Mesh to Top Rail-Bolt-on Aluminum 6 ft
- Mesh to Top Rail-Bolt-on Aluminum 8 ft
- Light Package<sup>1</sup>
- Soft Touch System
- Cold Weather Start Kit<sup>2</sup>
- Hostile Environment Kit<sup>3</sup>
- Flashing Amber Beacon
- Cold Package Plus<sup>4</sup>
- 52.8 gal. (200 L) Fuel Tank<sup>5</sup>
- Tool Tray
- Special Hydraulic Oils

- Includes platform mounted worklights and drive/backup lights.
- Includes battery heater and oil tank heater.
- Includes console cover, boom wipers and cylinder bellows.
- Includes extreme cold engine oil, fuel conditioner, engine block heater, battery blanket, glow plugs, hydraulic tank heater, and oversized footswitch. Arctic hydraulic oil priced separately.

Accessory Packages

- SkyWelder®
- SkyCutter®
- SkyGlazier®
- Nite Bright®
- Pipe Racks

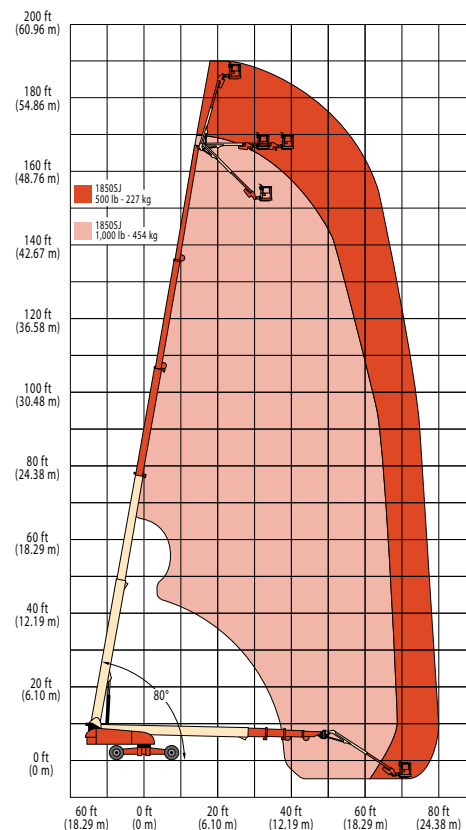

**JLG Industries, Inc.**

1 JLG Drive  
McConnellsburg, PA 17233-9533  
Telephone 717-485-5161  
Toll-free in US 877-JLG-LIFT  
Fax 717-485-6417  
**www.jlg.com**

An Oshkosh Corporation Company

Form No.: UB-BRO-0108  
Part No.: 3131561  
R021406  
Printed in USA

